

Installation & Operation Manual for VHM™ Series Arms



The purpose of this manual is to describe general installation, operation, and adjustment procedures for VHM™ Series Arms. This manual should be used in conjunction with any instrument-specific installation guides. Please read this manual and all instrument-specific installation material before installing or using this product.

Table of Contents

1.0 Installation, Operation, and Maintenance Warnings	2
2.0 Installing the VHM Arm in the Channel.....	3
3.0 Mounting the Instrument on the VHM Arm.....	5
4.0 Adjusting Counterbalance	6
5.0 Operating and Adjusting the VHM Arm	7
6.0 Cable Management	9
7.0 Routine Maintenance.....	10
8.0 Cleaning the Mounting Assembly	10
9.0 Troubleshooting the VHM Arm	11

1.0. Installation, Operation, and Maintenance Warnings

This section contains warnings regarding the installation, operation, and maintenance of the VHM Arm. This section must be read in its entirety before installing, operating, and maintaining the VHM Arm. Failure to follow these warnings may result in damage to equipment or injury to personnel.



Warnings

- Do not position the VHM Arm or mounted instrument above a patient. Note that the VHM ARM has a wide range of motion both up/down and side to side. Please consider carefully the instrument being mounted and the proximity of the mounting assembly to other equipment, hospital personnel, and the patient. GCX recommends that the hospital's risk management personnel verify that the application is appropriate prior to installation and use of the VHM Arm.
- If the VHM Arm is wall mounted, verify that the channel has been installed and approved in accordance with the channel installation guide.
- Ensure that the weight of the instrument being mounted does not exceed the load rating of the VHM Arm. Check the bottom surface of the Arm for the "Maximum Load" label (see 2.1 for label location).

- The Height Locking Lever or Knob must be engaged when removing a mounted instrument from the VHM Arm.

- Stand to the side of the VHM Arm and mounted instrument and use caution when disengaging the Height Locking Lever. The total mounted load may have changed due to the addition or removal of equipment (other than primary instrument) while the Height Locking Lever was engaged. A change in the total load can cause a sudden downward or upward movement of the Arm when the Height Locking Lever is disengaged.



- The mounted device or arm may move suddenly due to normal wear or improper adjustment of the tilt and swivel functions (see Sections 4.0, 5.2, 5.5, and 5.6) or ultimately, gas spring end of life. The VHM Arm must be inspected and adjusted at least two times per year. This inspection must include the following steps:
 - 1) With the device mounted, release the height lock and move the arm through its entire vertical range of motion. The load should maintain its position at every point in the travel of arm. If necessary, the counterbalance mechanism may be adjusted in accordance with section 4.0.
 - 2) Grasp the mounted device and swivel it from side to side. The device should swivel with some tension or resistance, not loosely. If necessary, the swivel tension may be adjusted in accordance with section 5.5.
 - 3) Grasp the Arm and pivot it from side to side at the channel attachment. The arm should pivot with some tension or resistance, not loosely. If necessary, the pivot tension may be adjusted in accordance with section 5.4.
 - 4) Grasp the mounted device and tilt it forward and back, through its entire range of motion. There should be enough tension or resistance in the tilt mechanism to prevent the device from tilting forward unexpectedly when in use. If necessary, the tilt tension may be adjusted in accordance with section 5.6.
 - 5) Inspect fasteners for looseness. Tighten as required for optimal operation and safety.
 - 6) Due to risk of personal injury or damage to the equipment, the VHM Arm housing must never be disassembled by non-GCX personnel. Failure to comply will void the warranty.

Failure to periodically inspect and adjust the Arm as instructed may result in damage to equipment or injury. If you do not intend to periodically inspect the arm, the Height Locking Lever should be removed entirely to reduce unexpected movement of the arm. If regularly inspected, the VHM Arm should function properly for 5 to 10 years. If you are unable to adjust the arm or require service, contact GCX technical support at 800-228-2555.

2.0 Installing the VHM Arm in the Channel

2.1 Thread the Height Locking Lever, *if provided, clockwise into the mounting hole in the right side of the Arm (below left). Turn Locking Lever clockwise to lock or counterclockwise to unlock. **Installation Note:** When the VHM arm is properly counterbalanced for the weight load, the arm will stay in the desired vertical position unless moved by the user. Engagement of the Height Locking Lever is necessary while changing the location of the entire Arm within the channel. Engagement of the Height Locking Lever is otherwise optional to prevent downward or upward movement. Refer to Section 3.0 (Adjusting Counterbalance) and Section 4.2 (Adjusting Height of the Mounted Instrument) for further information on use of the Height Locking Lever.

**VHM Arms with a Spring Lock are equipped at the factory with a Locking Knob (bottom of page).*



Note: The Height Locking Lever is a multi-position clamping lever that operates by lifting, rotating, and releasing the handle.

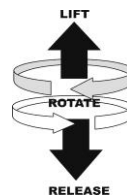

VHM Arm with Spring Lock

This type of VHM Arm is designed for use with transport monitors only. The Locking Knob is installed at the factory. Ensure Locking Knob is in locked position before attempting to mount Arm in channel.

Installation Note: For proper function of the locking mechanism, the arm must be properly adjusted to counterbalance the weight of the mounted instrument (see section 3.0).

Note: Locking Knob operates by pulling and releasing Knob.

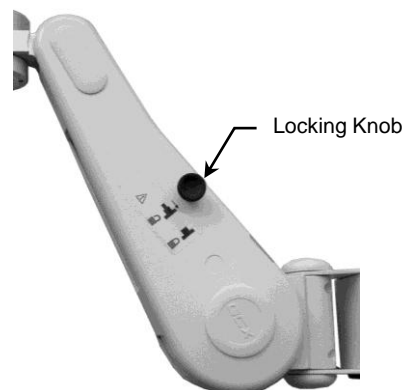

2.2 While supporting the *bottom of the Arm, guide the Slide into the top of the channel (below left) and move Arm to required mounting position.

2.3 Using the 1/8" hex wrench provided, tighten four (4) set screws in Slide to secure position of Arm (below right).

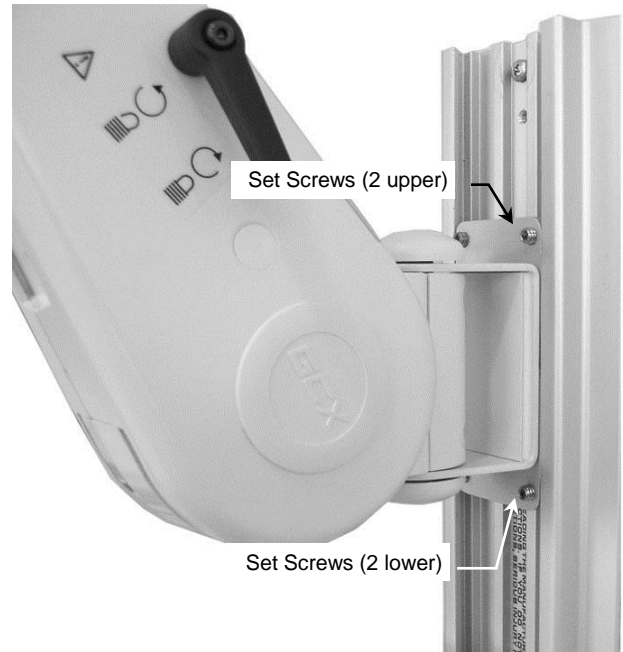

VHM Arm with Extension

VHM Arm with Extension may require additional support under the extension while mounting in channel. This type of Arm is designed to provide extension from the mounting surface for easier access and a wider range of motion. The Arm pivots both at the channel and at the attachment to the Arm. Different length Extensions have the same operational characteristics as other VHM Arms.

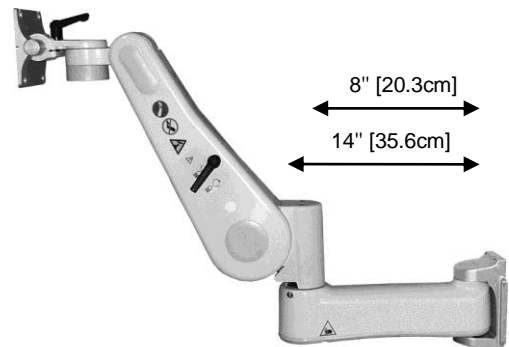
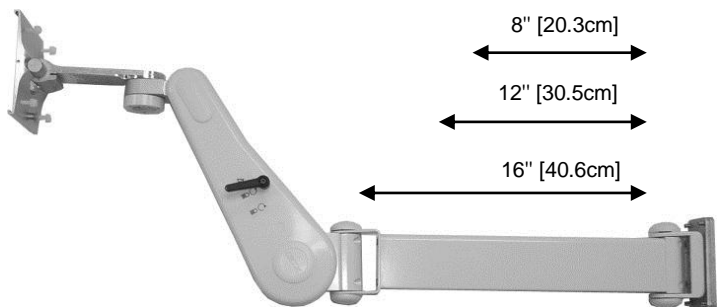

NG Extension

Installation Note: VHM Arm's with the NG Extension see *Installation & Operation Manual for VHM Series Extension* (DU- WS-0005-74) for additional Adjustment and Safety information.

3.0 Mounting the Instrument on the VHM Arm

Most instruments will require the attachment of an instrument-specific Mounting Adapter provided by GCX or by the instrument supplier. Please install the Mounting Adapter in accordance with the installation guide included with the Adapter.

3.1 Orientation of the Mounting Plate

The Mounting Plate Assembly should have either a Tilt Adjustment Lever installed for rear-mounted instruments or a Tilt Limit Screw for bottom-mounted instruments. In some cases, it may be necessary to remove or install either the Tilt Adjustment Lever or the Tilt Limit Screw prior to mounting the instrument. If the orientation of the Mounting Plate Assembly is not compatible with the instrument Mounting Adapter, refer to the procedures below and perform the appropriate modification.

Tilt Adjustment Lever: Insert and rotate clockwise to install. Rotate counterclockwise to remove. VESA Mounting Plate shown.

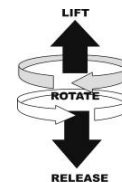

Note: The Tilt Adjustment Lever is a multi-position clamping lever that operates by lifting, rotating, and releasing the handle.

Tilt Limit Screw: Typically installed for bottom-mounted instruments, or removed for rear-mounted instruments. A 1/4" hex wrench will be provided for removal/installation of Tilt Limit Screw. Slide-on Mounting Plate shown.

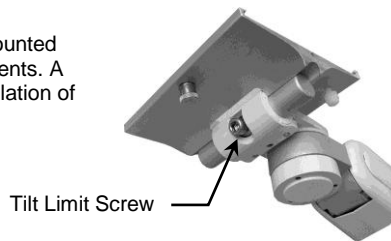

3.2 Mounting the Instrument



WARNING: The Arm must be **LOCKED IN THE HIGHEST POSITION** before an instrument is mounted on or removed from the Arm. This Warning does not apply to a VHM Arm with a Locking Knob.

Mount the instrument in accordance with your instrument-specific installation guide. **Installation Note:** VHM Arms will have either a "slide-on" or "VESA Standard" type Mounting Plate at the front of the Arm. In the absence of specific instructions, follow the applicable procedure below:

"VESA Standard" Type: Thread two (2) M4 screws into the top threaded holes of the 75 x 75mm mounting pattern, leaving 3mm of thread exposed. Lift the instrument onto the Mounting Plate by guiding the M4 screws into the slots in the Plate. Thread two (2) M4 screws into the lower mounting holes. Tighten all screws.

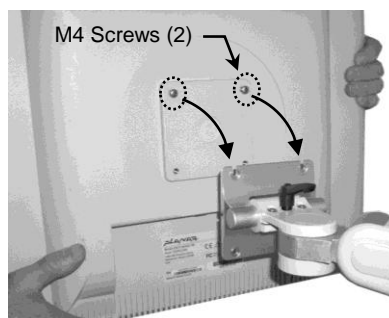

“Slide-on” Type: Pull the Plunger at the front of the Mounting Plate. Slide the instrument Mounting Adapter into the Mounting Plate until the Plunger snaps into the clearance hole in the Adapter. Tighten the Nylon screws on the rear or underside of the Plate.

Installation Note: A bottom-mounted instrument is shown here. The same procedure applies to rear-mounted instruments.

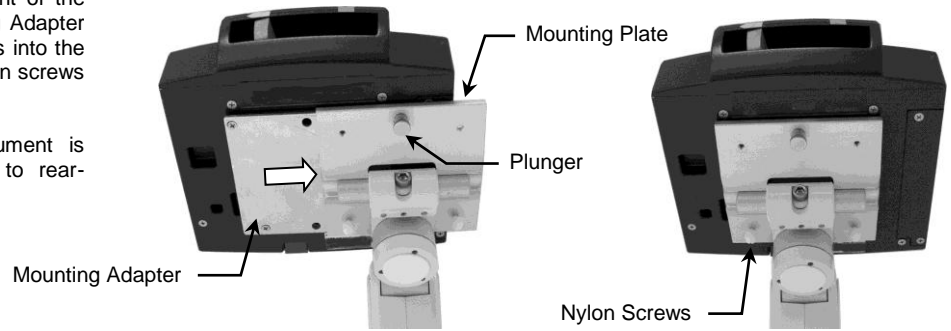

4.0 Adjusting Counterbalance



WARNING: Do not attempt counterbalance adjustment unless the instrument and accessories are mounted on the Arm. Use caution while performing this procedure.

The VHM Arm must be adjusted to counterbalance the mounted instrument throughout the Arm's vertical range of motion. When properly counterbalanced, the VHM Arm will maintain its height without engagement of the Height Locking Lever or Locking Knob. Because instrument weights vary, adjustment will typically be required to achieve optimal performance. A 1/2" [13mm] socket wrench is provided for this critical adjustment.

To adjust counterbalance:

- 4.1. Grasp the Arm behind the mounted instrument(s) and carefully move the Arm to a horizontal position that allows access to the Adjuster Cover (below left). Lock Arm in horizontal position.
- 4.2. Open the Adjuster Cover by inserting a flat blade screwdriver in the slot at the rear of the Cover and prying upward. If necessary unlock and readjust the Arm until the Counterbalance Adjuster bolt is accessible through the Adjuster Cover (below center). Lock Arm when Counterbalance Adjuster is accessible.
- 4.3. With the 1/2" [13mm] socket wrench on the Adjuster, carefully unlock the arm. Turn the Adjuster *counterclockwise (CCW)* to increase counterbalance force, or *clockwise (CW)* to decrease counterbalance force. Counterbalance is correctly adjusted when the mounted instrument can be moved up or down with minimal force and does not rise or fall after releasing the Arm.

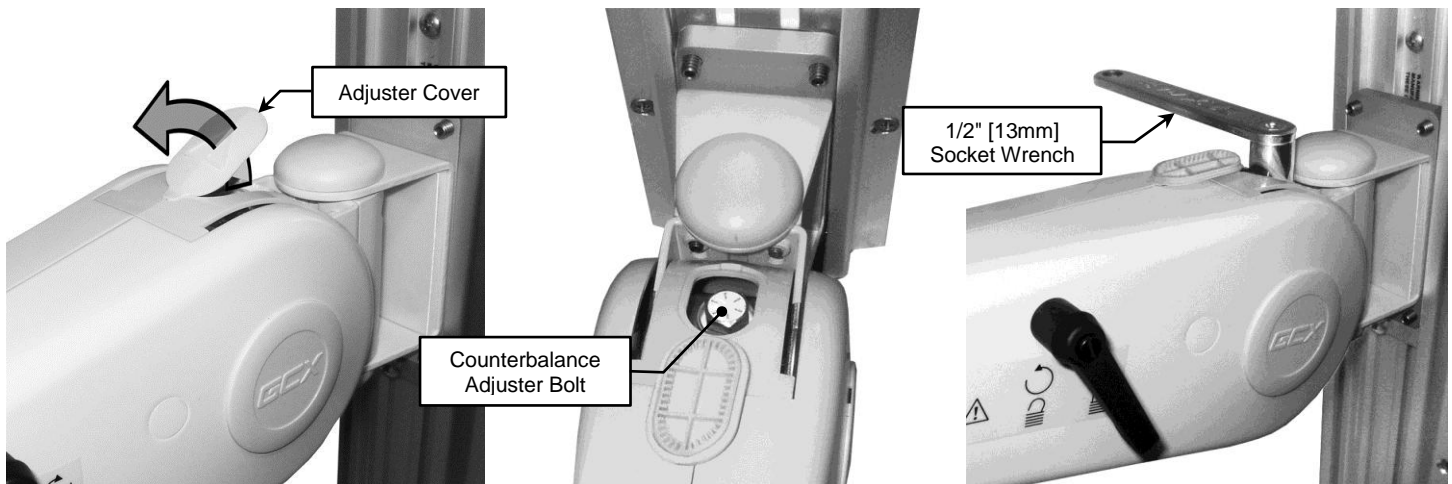

- 4.4. Close the Adjuster Cover.

5.0 Operating and Adjusting the VHM Arm

Check pivot, tilt, and front swivel mechanisms for proper tension. Refer to the applicable section and follow the adjustment procedure.

5.1 Counterbalance Adjustment – See Section 4.0

5.2 Adjusting Height of the Mounted Instrument



WARNING

- Do not attempt to adjust height without instrument being mounted on Arm.
- Stand to the side of the VHM Arm and mounted instrument and use caution when disengaging the Height Locking Lever. The total mounted load may have changed due to the addition or removal of equipment (other than primary instrument) while the Height Locking Lever was engaged. A change in the total load can cause a sudden downward or upward movement of the Arm when the Height Locking Lever is disengaged.



- 5.2.1. Grasp mounted instrument on sides (or handle) and move to desired height. When Arm is counterbalanced correctly (sec 4.0), it will maintain position when adjusted to a new height. **Note:** Disengagement/re-engagement of the Height Locking Lever may be necessary during vertical adjustment of mounted instrument (see **WARNING** above). Engagement of the Height Locking Lever is not required during normal operation of the counterbalanced instrument.

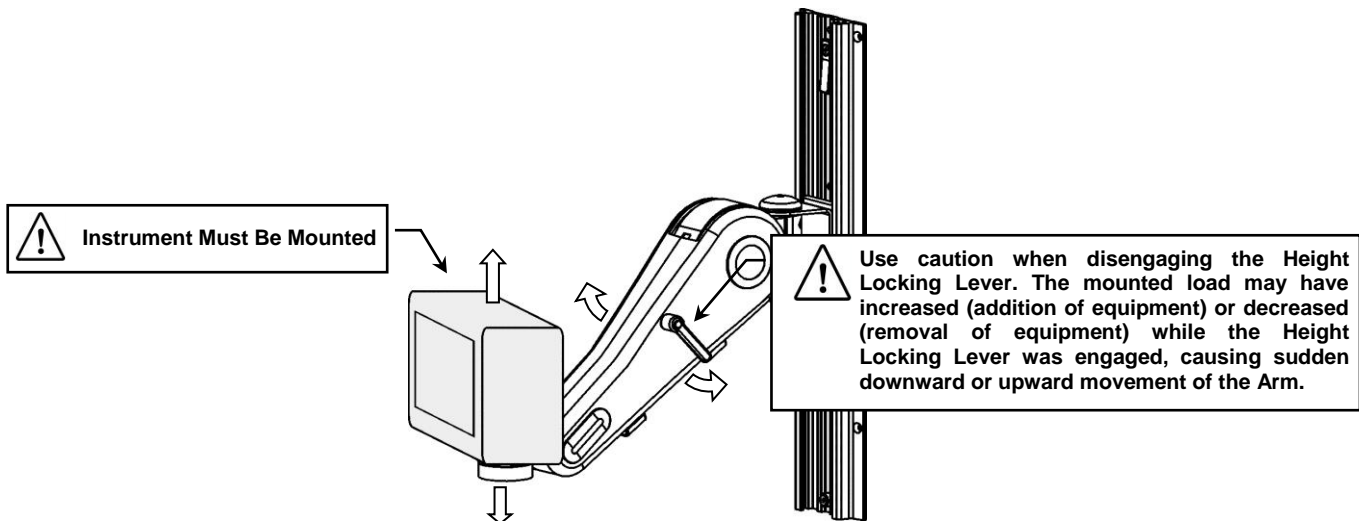

5.3 Positioning VHM Arm in Channel

 **Caution: Do not attempt to remove the Arm from the Channel while Arm is loaded with an instrument.**

- 5.3.1. Lock the Arm in highest vertical position using Height Locking Lever or Locking Knob.
- 5.3.2. Using the 1/8" hex wrench provided, loosen four (4) set screws in Slide.
- 5.3.3. Relieve the weight of the mounted instrument by lifting against the underside of the Arm, near the instrument. Simultaneously, push up or pull down the opposite end of the Arm immediately in front of the Slide.
- 5.3.4. Tighten four (4) set screws.

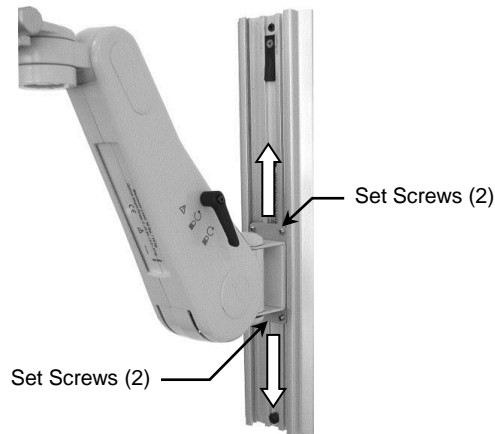

5.4 Pivoting the VHM Arm and Adjusting Pivot Tension

- 5.4.1. To pivot Arm at Channel, simply push on side of Arm.
- 5.4.2. To adjust pivot tension, remove upper and lower bolt caps from Pivot Bolt. Using the 1/2" [13mm] socket wrench provided and a 1/2" [13mm] box or open-end wrench, tighten or loosen Pivot Bolt and Hex Nut to desired tension. Reinstall bolt caps on each end of Pivot Bolt.

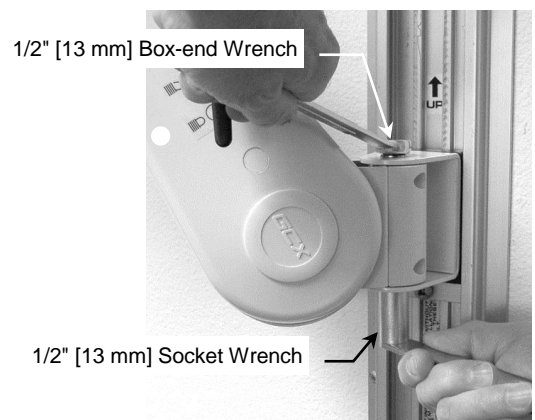

5.5 Swiveling the Mounted Instrument and Adjusting Swivel Tension

- 5.5.1. To swivel mounted instrument, simply push or pull instrument.
- 5.5.2. To adjust swivel tension, tighten or loosen the Swivel Tension Nut using the 1/2" [13 mm] socket wrench provided.
Installation Note: It may be necessary to remove an existing down post from the swivel cup to gain access to the Swivel Tension Nut.

 **Warning: Swivel tension nut must be torqued to a minimum of 20 in-lbs [2.3 N-m].**

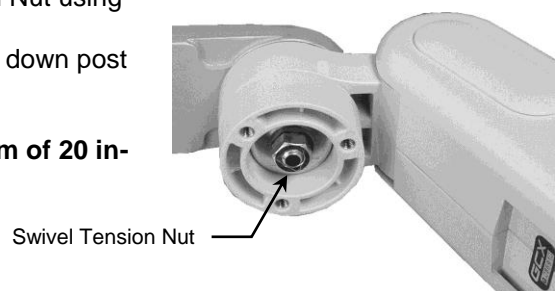

5.6 Adjusting Tilt Tension and Tilting the Mounted Instrument

In most configurations, the mounted instrument may be tilted and tilt tension may be adjusted.

- 5.6.1. Adjust tilt tension by equally tightening or loosening two (2) Tension Adjustment Screws with the 5/32" hex wrench provided. Once overall tilt tension is set, use Tilt Adjustment Lever to fine tune/lock tilt position.
- 5.6.2. Adjust tilt by loosening the Tilt Adjustment Lever (see **Note** below). Grasp the device and tilt to desired angle. Tighten Tilt Adjustment Lever to lock position.



Warning: Tilt tension screws must be torqued to a minimum of 35 in-lbs [4.0 N-m].

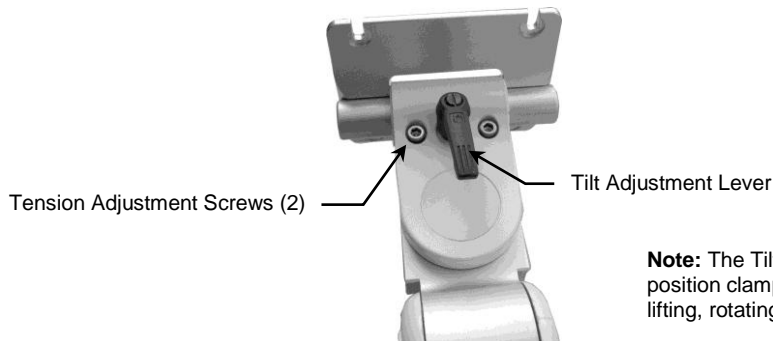

Note: The Tilt Adjustment Lever is a multi-position clamping lever that operates by lifting, rotating, and releasing the handle.

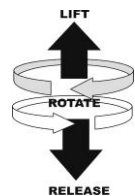

6.0 Cable Management

A Cable Guide is provided to facilitate routing of cables along the underside of the *arm. Squeeze the Cable Guide until its edges snap into the grooves in the bottom surface of the arm. Leave some extra cable loose at the front and rear of the arm to prevent cable binding, connector damage, or Cable Guide damage.

*Additional Cable Guides are provided for Arms with Extensions (see page 4). Guides snap into grooves on the bottom of the Extension.



7.0 Routine Maintenance

Periodically inspect all tilting, swiveling, pivoting, and mounting hardware. Tighten or adjust as necessary for optimal operation and safety.

8.0 Cleaning the Mounting Assembly

- 8.1. The mounting assembly may be cleaned with most mild, non-abrasive solutions commonly used in the hospital environment (e.g. diluted bleach, ammonia, or alcohol solutions).
- 8.2. The surface finish will be permanently damaged by strong chemicals and solvents such as acetone and trichloroethylene.
- 8.3. Steel wool or other abrasive material should *never* be used.
- 8.4. Damage caused by the use of unapproved substances or processes will not be warranted. We recommend testing any cleaning solution on a small area of the arm that is not visible, to verify compatibility.
- 8.5. Never submerge or allow liquids to enter the arm. Wipe any cleaning agents off of the arm immediately using a water-dampened cloth. Dry the arm thoroughly after cleaning.

CAUTION: GCX makes no claims regarding the efficacy of the listed chemicals or processes as a means for controlling infection. Consult your hospital's infection control officer or epidemiologist. To clean or sterilize mounted instruments or accessory equipment, refer to the specific instructions delivered with those products.

9.0 Troubleshooting the VHM Arm

Symptom	Possible Cause	Remedy
Mounted instrument does not appear level or parallel to the floor.	Channel not plumb. Check with level.	Adjust Channel to plumb, or reinstall Channel.
	Weight of instrument not compatible with Load Rating of the Arm.	Mount instrument on arm with compatible Load Rating.
	Swivel hardware loose.	Adjust Swivel Nut (section 5.5).
	Pivot hardware loose.	Adjust Pivot Bolt (section 5.4).
	Mounting surface (e.g. wall, side of anesthesia machine, etc.) not structurally sound (does not hold mounting hardware).	Mounting surface must be reinforced or Channel must be relocated.
	Channel loose at mounting surface.	Check for plumb and tighten, or relocate (reinstall) Channel.
	Set Screws (4) in Slide are loose.	Reposition Arm and tighten set screws.
Instrument drifts up or down when the Arm is unlocked.	Arm not counterbalanced correctly for weight of the instrument.	Perform counterbalance adjustment per section 4.0.
	Weight of mounted instrument (load) not compatible with Load Rating of Arm.	Use arm with compatible Load Rating, and perform counterbalance adjustment per section 5.0.
Arm pivots too freely.	Pivot Bolt too loose.	Adjust Pivot Bolt (section 5.4).
Arm does not pivot easily.	Pivot Bolt too tight.	
Instrument swivels too freely.	Swivel Nut too loose.	Adjust Swivel Nut (section 5.5).
Instrument difficult to swivel.	Swivel Nut too tight.	
Instrument difficult to tilt.	Tilt Adjustment Lever too tight.	Adjust tilt and tilt tension per section 5.6.
	Excessive tilt tension.	
Instrument will not maintain tilt position.	Tilt Adjustment Lever too loose.	
	Insufficient tilt tension.	
Arm difficult to move up or down when unlocked.	Arm not counterbalanced correctly for weight of mounted instrument.	Perform counterbalance adjustment per section 4.0.
Arm inadvertently slides down Channel.	Set Screws (4) in Slide are loose.	Reposition Arm and tighten set screws.
Locking Knob (Arms with Spring Lock) will not pull out (release).	Arm not counterbalanced correctly for weight of mounted instrument.	Perform counterbalance adjustment per section 4.0.
	Weight of mounted instrument (load) not compatible with Load Rating of Arm.	
Counterbalance Bolt difficult to adjust.	Arm not locked in a horizontal position.	Reposition Arm and lock in horizontal position.

GCX Mounting Assembly Installation Guide

Ergo Bracket

The purpose of this guide is to:

1. Describe attachment of the Ergo Bracket to a roll stand, VHM arm, and M-Series Arm.
2. Describe attachment of a keyboard tray to the Ergo Bracket.
3. Describe mounting of a flat panel display to the Ergo Bracket.
4. Describe attachment of Vertical Extension to Ergo Bracket.

Parts Reference

The following parts and hardware are included with this installation kit (see photos for parts; hardware not shown):

Item #	Description	Qty
1	Ergo Bracket	1
2	75/100mm Flat Panel Adapter Assy – Packaged Separately (includes attachment hardware)	1
3	Horizontal Extension – Ergo Bracket to VHM Arm	1
4	Vertical Extension – Manual Tilt/Mounting Plate Assy. to Ergo Bracket	1
5	#10-32 x 3/4" Flat Head Machine Screw (FHMS) – Vertical Extension to Ergo Bracket	3
6	#10-32 x 3/4" FHMS – Extension to Mount (roll stand, wall, or arm)	3
7	#10-32 x 5/8" FHMS – Ergo Bracket to Roll Stand	3
8	#10-32 x 7/16" FHMS – Ergo Bracket to Extension	3
9	#10-32 x 5/16" FHMS (100°) – Keyboard Tray to Ergo Bracket	4
10	#10-32 x 7/16" FHMS – Keyboard Plate to Ergo Bracket	3
11	Lexan Cover, Black - Covering Screw Heads on Vert Ext and Manual Tilt Clamp	2
12	9/64" Hex Wrench – Tilt Tension Adjustment	1

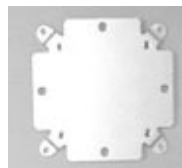

Flat Panel Adapter



Vertical Extension

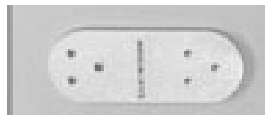

Horizontal Extension



Ergo Bracket

Tools Required: Phillips screwdriver.

Attachment of Ergo Bracket to Roll Stand

Align the 3-hole pattern in the Ergo Bracket (Pic 1) with three (3) threaded holes in top of the Roll Stand Post (Pic 2). Fasten Bracket to Post with three (3) #10-32 x 5/8" FHMS (Pic 3).

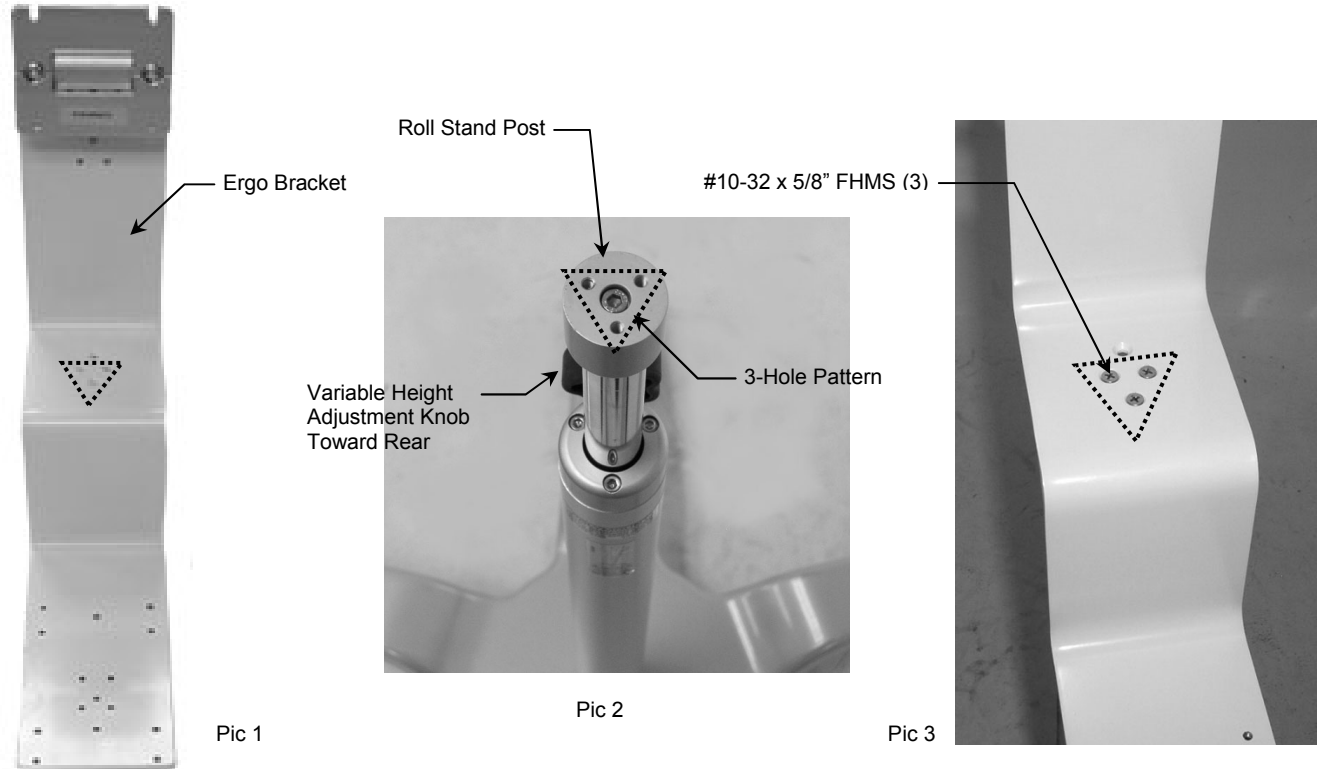

Attachment of Ergo Bracket to VHM Arm

Align the three (3) threaded holes on the VHM arm (Pic 4) with the 3-hole pattern on the Horizontal Extension (Pic 5). Fasten Extension to Arm with three (3) #10-32 x 3/4" FHMS.

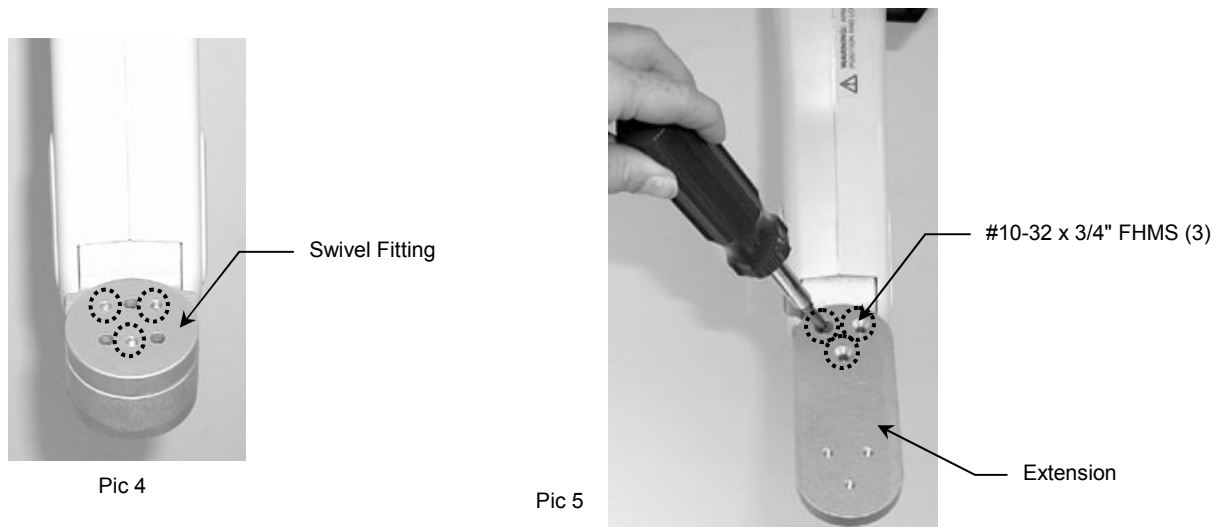

2. Align the 3-hole pattern on the opposite end of the Extension (Pic 6) with the 3-hole pattern shown on the Ergo Bracket (Pic 7). Fasten Bracket to Extension with three (3) #10-32 x 5/8" FHMS (Pic 8).

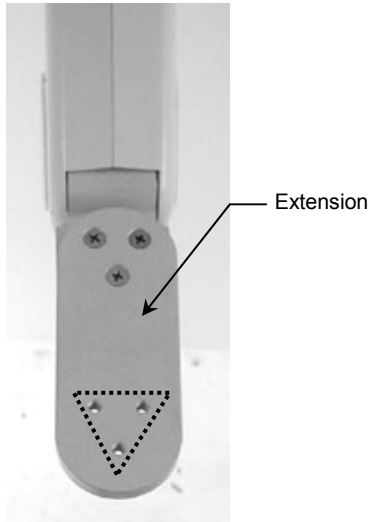

Pic 6

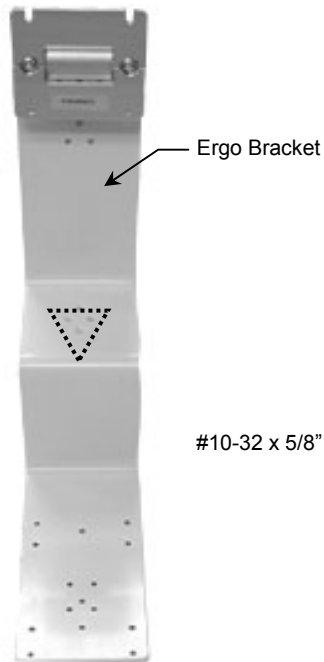

Pic 7

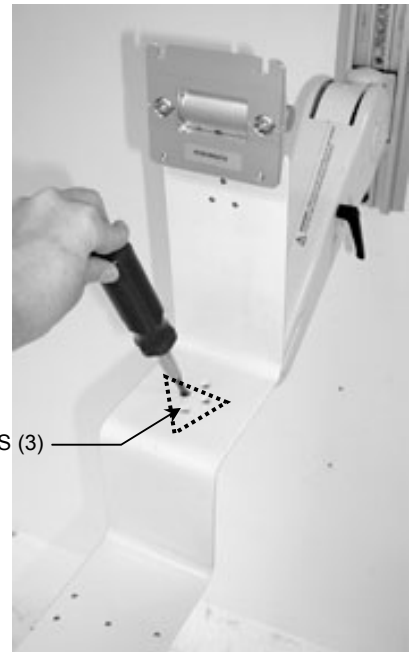

Pic 8

Attachment of Ergo Bracket to M-Series Arm

Align the threaded 3-hole pattern on the Swivel Fitting with the 3-hole pattern on the Ergo Bracket. Fasten Bracket to Arm with three (3) #10-32 x 5/8" FHMS.

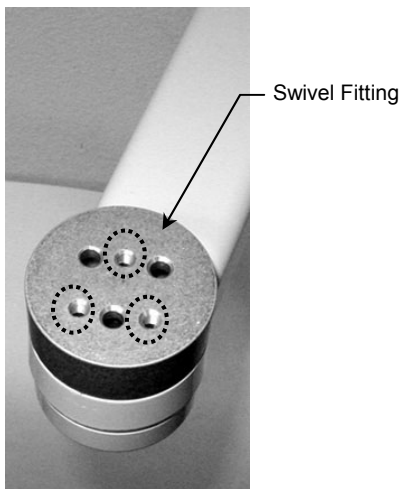

Pic 9

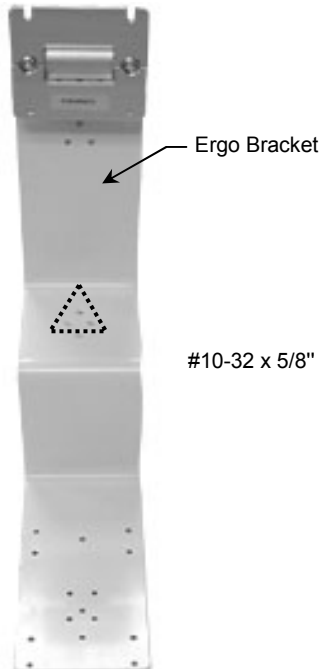

Pic 10

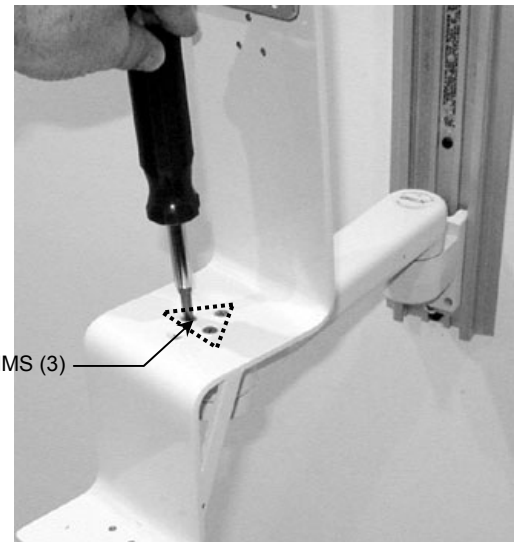

Pic 11

Attaching Keyboard Tray and Plate to Ergo Bracket

Keyboard Tray

Align the 4-hole mounting pattern on the Ergo Bracket (Pic 12) with the 4-hole pattern on the Keyboard Tray (Pic 13) and secure the Tray to the Bracket using four (4) #10-32 x 5/16" FHMS-100° (Pic 14). **Note:** For greater separation between keyboard and display screen, a second mounting pattern is provided to mount the Keyboard Plate closer to the front of the Ergo Bracket. **Installation Note:** It may be necessary to slide both left and right mouse trays outward a few inches (Pic 14) before attaching the Keyboard Tray to the Bracket.

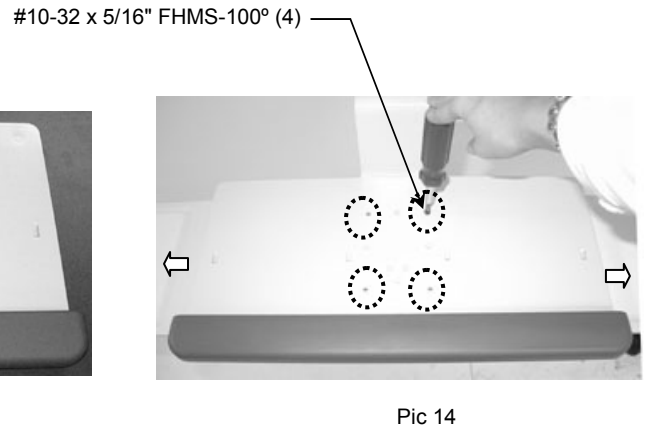
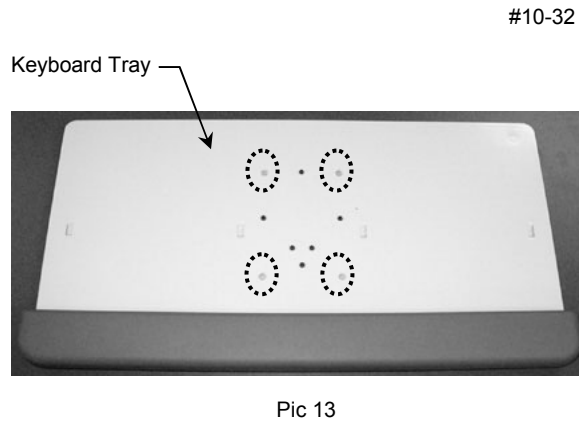
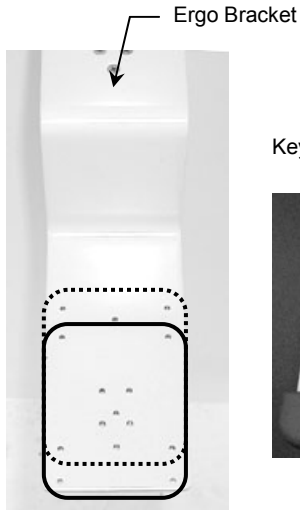

Keyboard Plate

Align the 3-hole mounting pattern on the Ergo Bracket (Pic 15) with the 3-hole pattern on the Keyboard Plate (Pic 16) and secure the Plate to the Bracket using three (3) #10-32 x 7/16" FHMS (Pic 17). **Note:** For greater separation between keyboard and display screen, a second mounting pattern is provided to mount the Keyboard Plate closer to the front of the Ergo Bracket.

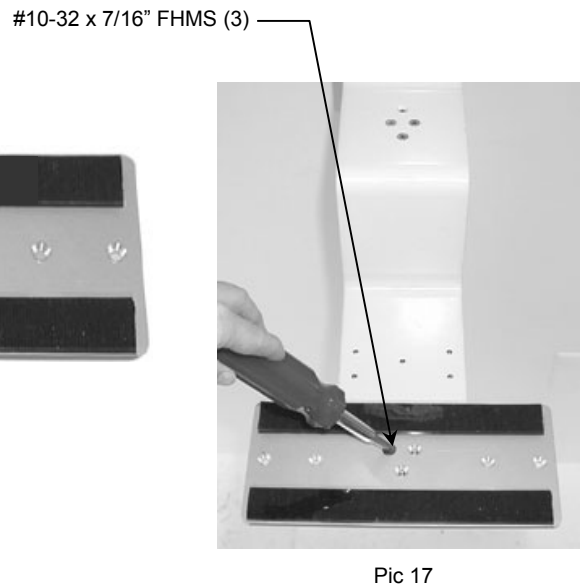
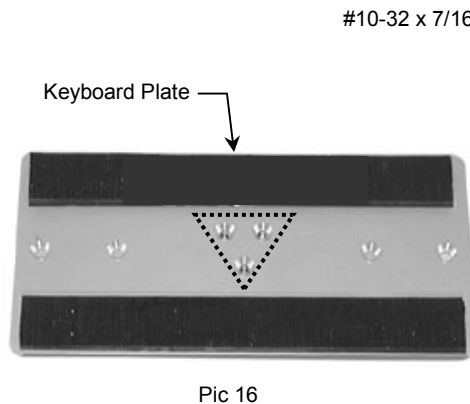
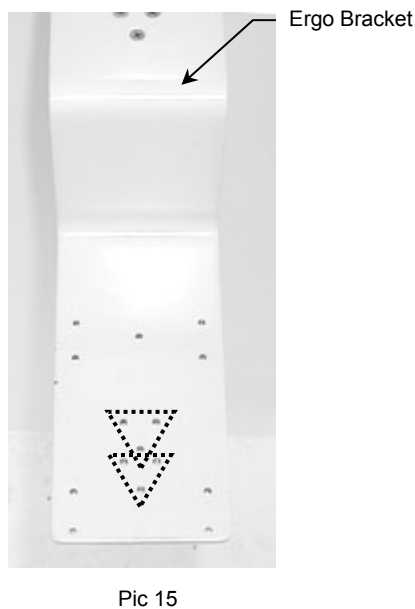

Mounting a Flat Panel Display on the Ergo Bracket

Installation Note

A Flat Panel Mounting Adapter Kit (included) is required if the display being mounted has a 100 x 100mm mounting pattern on the rear of the housing. Below is a quick procedure for mounting a display with a 75 x 75mm mounting pattern. Refer to *DU-FLP-0002-17* (included with the Mounting Adapter Kit) for complete mounting procedures.

Mounting a Flat Panel Display with a 75 x 75mm VESA Mounting Pattern

An assortment of M4 pan head machine screws (PHMS) is provided with the Mounting Adapter Kit. Determine the appropriate length screw for your application before mounting the display.

1. Insert two (2) M4 PHMS in the top threaded holes of the display housing (Pic 18), leaving 4mm of screw thread exposed.
2. Guide the top two (2) screws into the slots in the Mounting Plate and tighten (Pic 19).
3. Tilt the display upward for access to the bottom of the Mounting Plate and insert two (2) M4 PHMS in the remaining mounting holes (Pic 20).

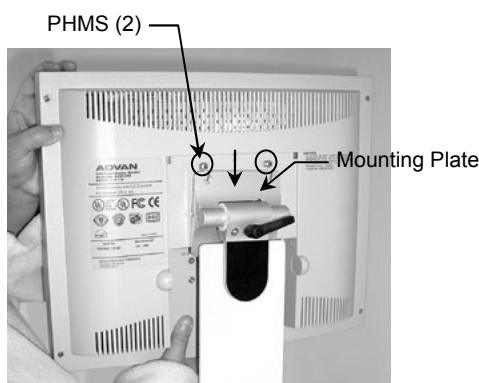

Pic 18

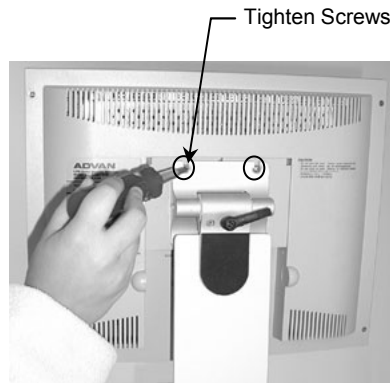

Pic 19

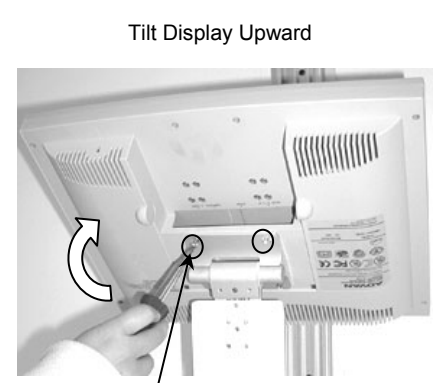

Pic 20

Mounting Larger Flat Panel Displays

A Vertical Extension is provided with this installation kit to allow the Ergo Bracket to accommodate larger Flat Panel Displays. The following procedure describes attachment of the Vertical Extension.

Attaching the Vertical Extension

1. Remove the Lexan Cover from the Manual Tilt/Mounting Plate Assembly and unscrew three (3) #10-32 x 7/16" FHMS (Pic 21). Retain these three screws for use in Step 3.

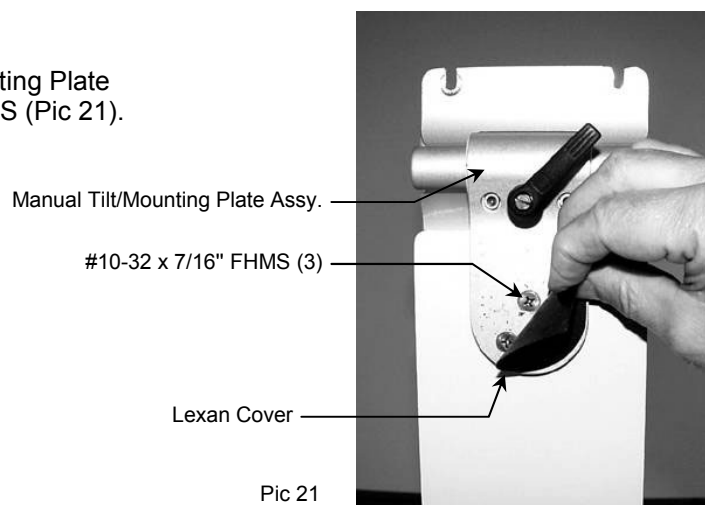

Pic 21

Installation Note: Four (4) mounting positions are provided for vertically extending the Display mount: two (2) positions on top of the Ergo Bracket (Pic 22) and two (2) positions on the Vertical Extension (Pic 24).

2. Select the desired mounting height for your Display and attach the Vertical Extension to the Ergo Bracket using three (3) #10-32 x 3/4" FHMS (Pic 23).

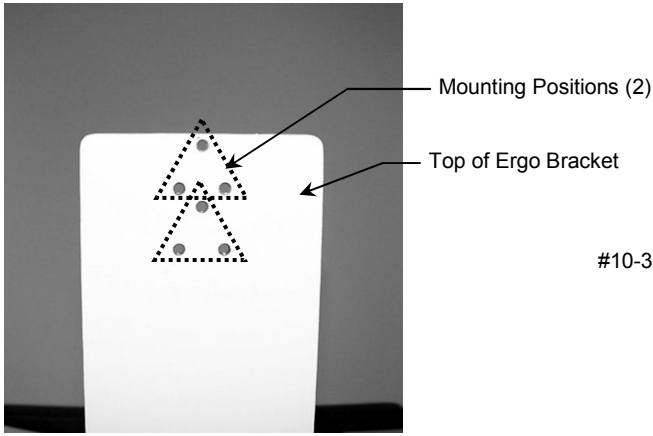

Pic 22

#10-32 x 3/4" FHMS (3)

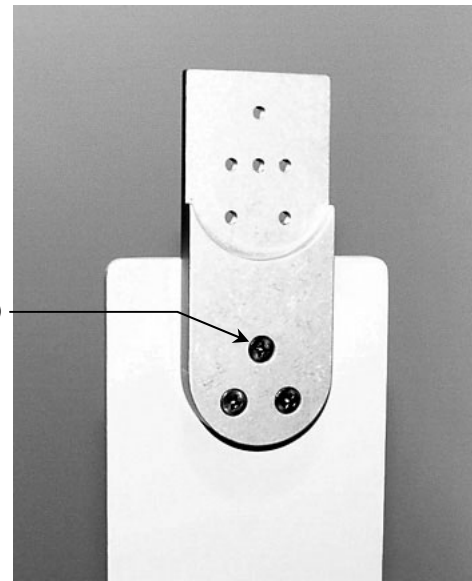

Pic 23

3. Select the desired mounting position (Pic 24) and attach the Manual Tilt/Mounting Plate Assembly to the Vertical Extension using the three (3) #10-32 x 7/16" FHMS removed in Step 1 (Pic 24). **Note:** New Lexan Covers are provided for covering screw heads on the Vertical Extension and Manual Tilt/Mounting Plate Assembly. Peel off backing and place new covers over the screw heads if desired.

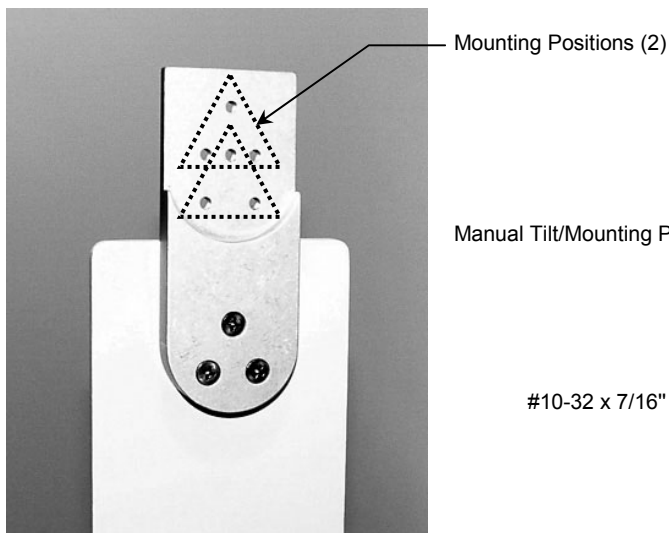

Pic 24

Manual Tilt/Mounting Plate Assy.

#10-32 x 7/16" FHMS (3)

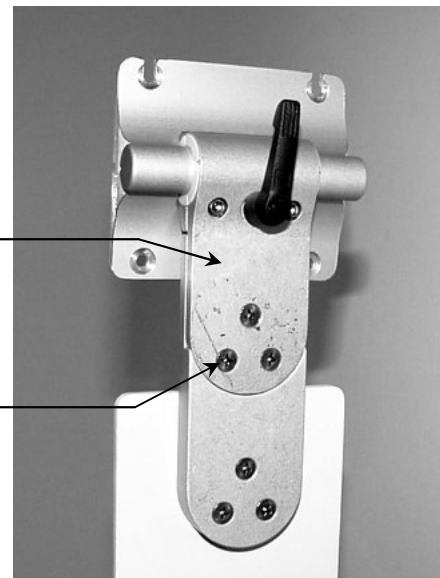

Pic 25

4. Mount the Flat Panel Display in accordance with *DU-FLP-0002-17*.

Installation Guide

Bottom Cover for Wall Mount Keyboard Tray
(Refer to qualified personnel)

Purpose:

To describe the installation of the Bottom Cover for Wall Mount Keyboard Tray

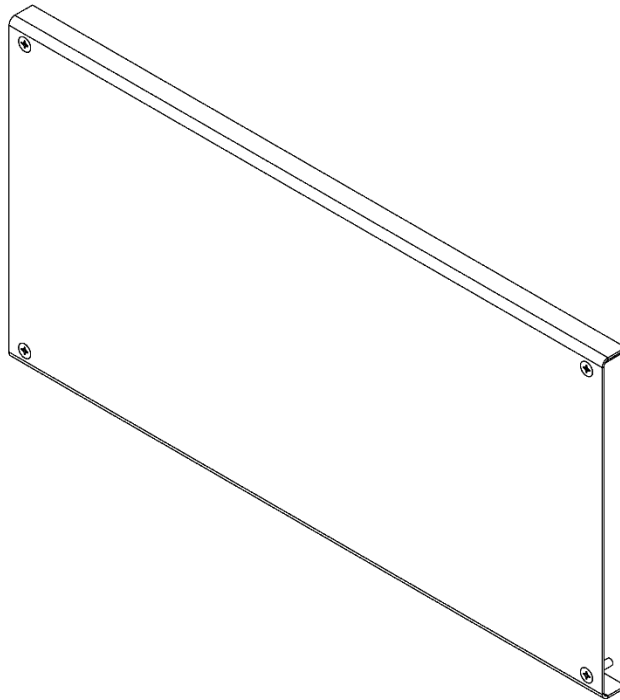

Parts Reference

The following parts and hardware are included in this installation kit:

Item #	Description	Qty.
1	Bottom Cover for Keyboard Tray	1
2	10-32 x 3/4" x 100° FHMS	2
3	10-32 x 1" x 100° FHMS	2

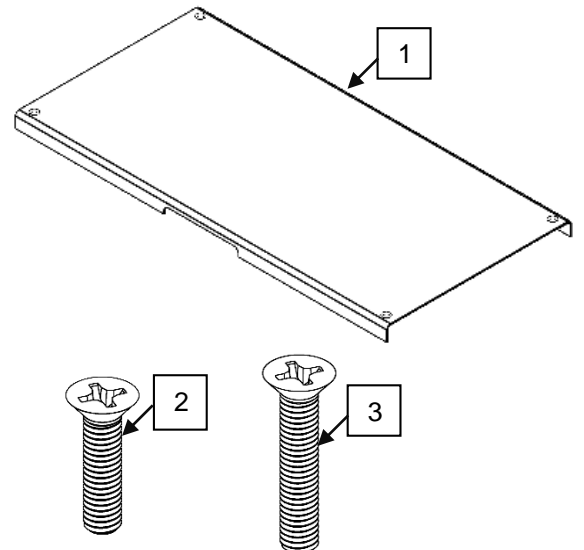

Tools Required:

- Phillips Screwdriver (Not included)

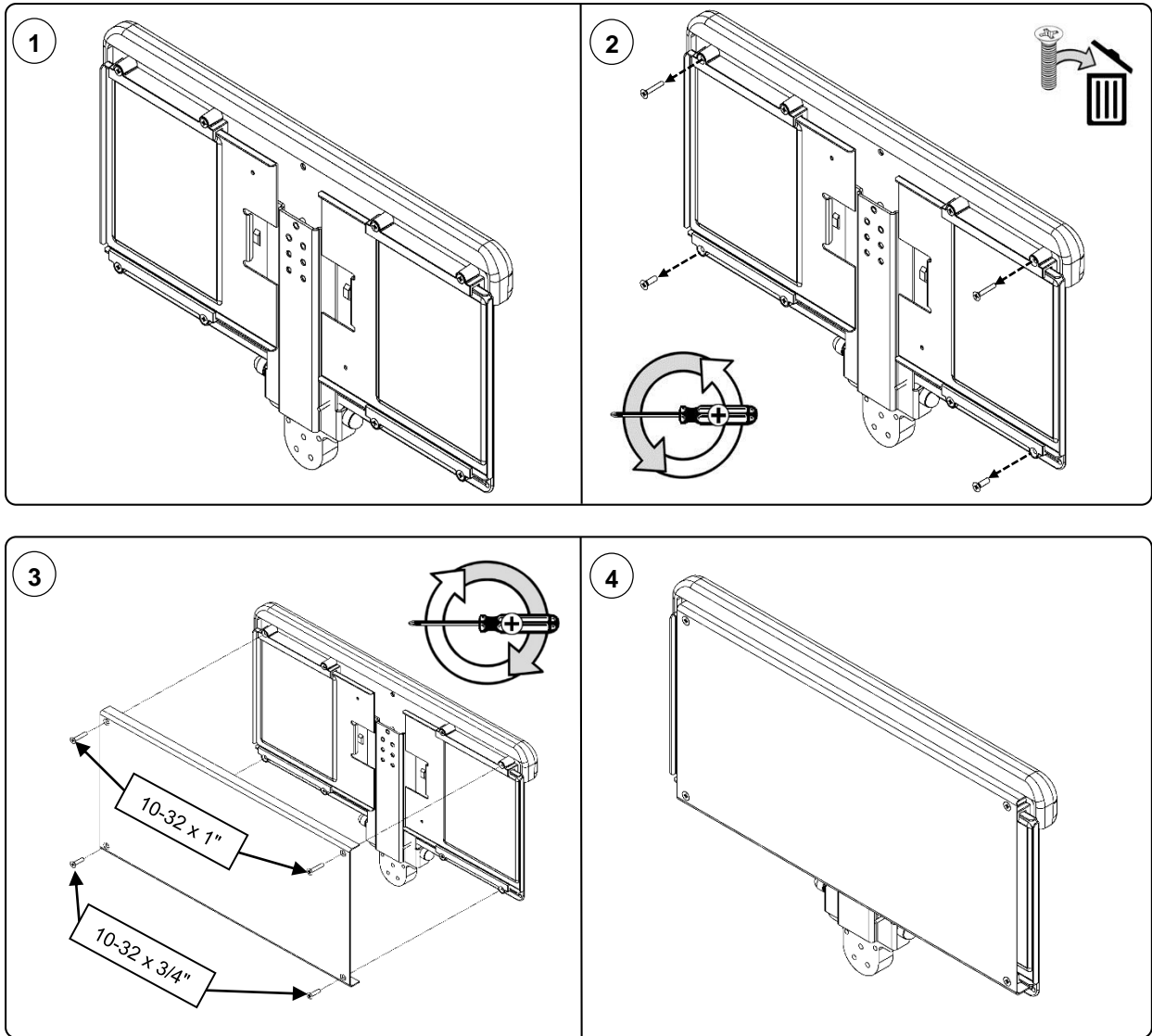

Routine Maintenance

Periodically inspect all fasteners associated with the mounting assembly. Tighten or Adjust as necessary for optimal operation and safety.

Cleaning the Mounting Assembly

1. The mounting assembly may be cleaned with most mild, non-abrasive solutions commonly used in the hospital environment (e.g. diluted bleach, ammonia, or alcohol solutions).
2. The surface finish will be permanently damaged by strong chemicals and solvents such as acetone or trichloroethylene.
3. Steel wool or other abrasive material should never be used.
4. Damaged caused by the use of unapproved substances or processes will not be warranted. We recommend testing of any cleaning solution on a small area of the mounting assembly that is not visible to verify compatibility.
5. Never submerge or allow liquids to enter the mounting assembly. Wipe any cleaning agents off the mounting assembly immediately using a water-dampened cloth. Dry the assembly thoroughly after cleaning.

CAUTION: GCX makes no claims regarding the efficacy of the listed chemicals or processes as a means for controlling infection. Consult your hospital's infection control officer or epidemiologist. To clean or sterilize mounted devices or accessory equipment, refer to the specific instructions delivered with those products.